

A Bio-Inspired Image Processor for Edge Detection with Single-Electron Circuits

Andrew Kilinga Kikombo^a, Alexandre Schmid^b, Tetsuya Asai^a, Yusuf Leblebici^b, and Yoshihito Amemiya^a

^aGrad. Sch. of Information Science and Technology, Hokkaido University, Japan, kikombo@sapiens-ei.eng.hokudai.ac.jp

^bMicroelectronic Systems Laboratory, Swiss Federal Institute of Technology (EPFL), Switzerland

Single-electron circuits can be considered as highly functional units both in digital and analog computational systems [1]. On the other hand, electrical circuits that are designed by mimicking computational structures in living organisms—neuromorphic circuits, would provide an insight to develop even more efficient processors. Neuromorphic systems have extensively been studied only for CMOS devices, and several neuromorphic circuits have been designed and fabricated [2-3]. In this work, as an example toward developing *nano-electronic neuromorphic architectures*, we propose a possible image-processing structure for single-electron circuits. Among early visual processing, edge detection is a primary function in the vertebrate retina. We thus propose a single-electron circuit performing edge detection, and demonstrate the basic operations.

The vertebrate retina consists of massively interconnected neural cells in a hierarchical structure where edge detection is carried out mainly through three types of cells: (i) photoreceptors which transduce light into electrical signals, (ii) horizontal cells which receive inputs from the superjacent layer of photoreceptors, and produce spatially-averaged outputs in relation to the inputs, and (iii) bipolar cells that produce the difference in amplitudes between the outputs of photoreceptors and horizontal cells [3]. The schematic model is shown in Fig. 1(a). We assume that illuminated (or non-illuminated) photoreceptors produce low (or high) potentials (Fig. 1(b)-P). The outputs are spatially averaged by horizontal cells (Fig.1(b)-H). The difference in amplitudes between photoreceptors and horizontal cells is obtained by subtracting “H”- from their corresponding “P”-values in bipolar cells. Therefore, the non-zero outputs of bipolar cells represent positions of edges in the input image (Fig. 1(b)-B).

We propose a neuromorphic architecture based on the retinal model above with single-electron oscillators [4]. A single-electron oscillator consists of a tunneling junction C_j , resistance R and a bias voltage source (see insets in Fig. 2). When a positively-biased (or negatively-biased) oscillator is illuminated, photo-induced electron tunneling in C_j occurs [5-6], which leads to voltage drop (or increase) at the node (\bullet in Fig. 2) because of electron tunneling from the ground (or node) to the node (or ground).

We implement a retinal photoreceptor with a positively-biased oscillator that is triggered by external light inputs. Horizontal cells are constructed by resistively-coupled single-electron oscillators (positive bias), to emulate extensive gap junctions in retinal cells. Subtractive functions in bipolar cells can qualitatively be imitated by neural excitation and shunting inhibition mechanisms. Figure 2 shows fundamental circuits for neural excitation and inhibition with single-electron oscillators. Let us assume that electron tunneling occurred in both P and H. This triggers a signal flow along both branches as follows. Electron tunneling in P leads to node voltage drop in Bl_1 below its threshold (thus inducing it to tunnel), while H induces Br_1 to tunnel. In the left branch, Bl_1 in turn induces tunneling in Bl_2 , which in turn induces tunneling in O (excitation). Simultaneously, tunneling in P activates Br_2 because of the capacitive coupling between them. This decreases the node voltage of Br_2 , and thus restrains it from tunneling (inhibition). Therefore, signals initiating from H in the right branch are blocked. With these excitatory and inhibitory configurations, we partly imitate subtractive functions of bipolar cells.

A unit pixel circuit is shown in Fig. 3. Photoreceptors are connected to the horizontal cells through unidirectional-coupling circuits that allow signals to flow from the photoreceptors to horizontal cells (not in the opposite direction) [7-8]. In the presence of the light input, electron tunneling occurs at the photoreceptor, which induces subsequent electron tunneling in the immediate horizontal cells. The horizontal cells then trigger a signal flow (successive tunneling events in the bipolar cells) toward the corresponding output oscillators. Simultaneously, photoreceptors inhibit positively-biased oscillators in bipolar cells, blocking signal flow in the corresponding right branch. Otherwise, if the neighboring pixel was not illuminated, the signal would flow in the left branch and lead to subsequent tunneling. Through this process, the circuit detects the edge position, i.e., positions of bipolar cells where electron tunneling happened.

To confirm the basic operation, we constructed a one-dimensional array circuit consisting of 100 pixel circuits. The light input was incident upon photoreceptors from number 30 to 70, as shown in Fig. 4 (labeled 'input'). We assumed that photoreceptors were illuminated with single photons. The outputs of horizontal cells are plotted in the same figure ('horizontal layer'), whereas the output of bipolar cells, representing the position of the edges, is shown as 'output' in the figure. We confirmed that electron tunneling certainly happened at the output nodes of bipolar cells where the edges exist in the corresponding photoreceptors. For gray-scale input images, since tunneling rates of photoreceptors would be proportional to the intensity of the light input, we may estimate the edge position by evaluating the tunneling rates of bipolar cells.

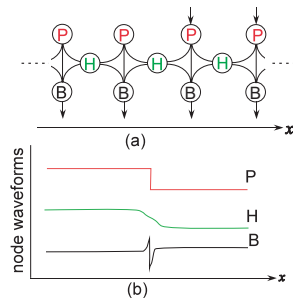

Fig. 1 Model for edge detection
(a) Hierarchical structure of retina
(b) Process of edge detection

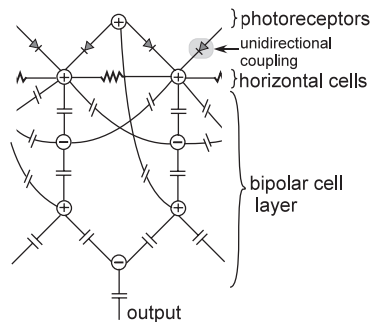

Fig. 3 Unit pixel of the edge detecting circuit

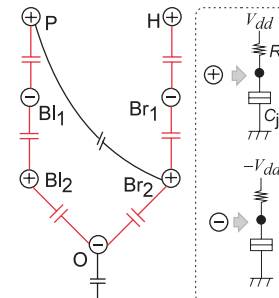

Fig. 2 Realizing the bipolar cell

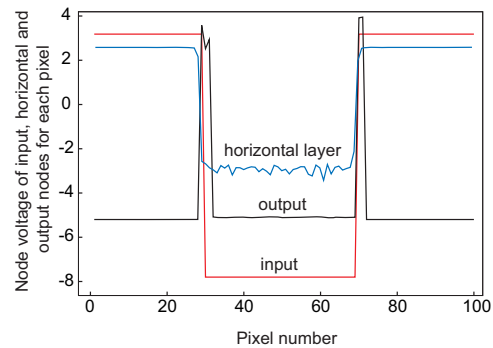

Fig. 4 Input and output waveforms of a sample 100-pixel circuit.

References

- [1] Christoph Wasshuber, "Computational Single-Electronics," Wien: Springer, 2001.
- [2] Carver Mead, "Analog VLSI and Neural Systems," Addison-Wesley, 1989.
- [3] Shih-Chii Liu *et al.*, "Analog VLSI: Circuits and Principles," Massachusetts: MIT Press, 2002.
- [4] M. H. Devoret and H. Grabert, "Single Charge Tunneling," New York: Plenum, 1992.
- [5] A. Fujiwara, Y. Takahashi, and K. Murase, *Phys. Rev. Lett.*, 78, 1532-1535, 1997.
- [6] R. Nuryadi, Y. Ishikawa, and M. Tabe, *Phys. Rev. B*, 73, 45310-45316, 2006.
- [7] T. Oya T., A. Schmid, T. Asai, Y. Leblebici and Y. Amemiya, *IEICE Electronics Express*, 2, no. 3, pp. 76-80, 2005.
- [8] T. Oya, T. Asai, R. Kagaya, T. Hirose and Y. Amemiya, Proc. Int. Symp. on Nolta, pp. 235-239, 2004.