

Pulsed neural networks consisting of single-flux-quantum spiking neurons

T. Hirose ^{*}, T. Asai, Y. Amemiya

Department of Electrical Engineering, Hokkaido University, Kita 14, Nishi 9, Kita-ku, Sapporo 060-0814, Japan

Received 31 October 2006; received in revised form 29 January 2007; accepted 6 February 2007

Available online 29 May 2007

Abstract

An inhibitory pulsed neural network was developed for brain-like information processing, by using single-flux-quantum (SFQ) circuits. It consists of spiking neuron devices that are coupled to each other through all-to-all inhibitory connections. The network selects neural activity. The operation of the neural network was confirmed by computer simulation. SFQ neuron devices can imitate the operation of the inhibition phenomenon of neural networks.

© 2007 Elsevier B.V. All rights reserved.

PACS: 74.81.Fa; 74.90.+n

Keywords: Single-flux-quantum; Spiking neuron device; Integrate-and-fire neuron; Pulsed neural network

1. Introduction

Brain-like information processing – an attempt to imitate human intelligence with electronic devices – is a promising area of research in electronics. To achieve brain-like processing with electronic devices, we must develop a way of constructing electrical analogs of biological neural systems. For this purpose, we previously developed leaky integrate-and-fire neuron (IFN) devices consisting of single-flux-quantum (SFQ) circuits [1]. In this work, we used SFQ circuits to construct inhibitory neural networks that can perform pulsed-based computation for intelligent information processing.

In biological neural networks, neurons communicate with each other by using spike trains of action potentials, or neural code. Information is encoded into spike trains of temporal neural code and is carried to other neurons. The code is processed by the neurons in a network, and

the network shows dynamic temporal characteristics, e.g., synchronization, noise tolerance, and neural activity selection [2–5]. Several electrical neuron systems have been developed experimentally to imitate neural network characteristics [4]. However, the stiff response of spiking neurons prevents us from simulating large-scale spiking neural networks on conventional digital computer systems because the time-step values in the simulation have to be chosen to be much smaller than the spike width. Unlike other electronic devices, a medium for signals in SFQ circuits is a pulse of a fluxoid quantum, therefore SFQ circuits are able to imitate the operation of neurons more precisely. SFQ implementation of the networks enables studying dynamic properties independent of system size, which implies that the neural SFQ circuit is a possible tool for developing an artificial neural system that is superior to our central nervous system. In the following sections, we first outline the inhibitory neural network model and describe the IFN devices consisting of SFQ circuits (Section 2), and then we describe its circuit implementation and demonstrate the operation of the neural network by means of computer simulation (Section 3).

^{*} Corresponding author. Tel.: +81 11 706 7149; fax: +81 11 706 7890.
E-mail address: hirose@sapiens-ei.eng.hokudai.ac.jp (T. Hirose).

2. Construction of a pulse-based neural network

2.1. Network model for the mutual inhibiting

Spike timing neural code performs selection of neural activities using a network of mutual inhibiting neurons [5]. Activity selection in a neural network depends on the timing of neuron stimulation by spike trains. Fig. 1 shows the inhibitory neural network system. The neurons are coupled to each other through all-to-all inhibitory connections of equal strength. The network consists of a number of neurons and a global inhibitor (GI). Each neuron accepts input pulses and produces corresponding output pulses. The global inhibitor receives the sum of the output pulses and produces an inhibitory output that is sent to all neurons. The network enables selection of neuron activity. Neurons receiving frequent input pulses increase their internal state for firing and produce output pulses frequently. The output pulses are transmitted to all of neurons through the global inhibitor and reduce the internal state of the neurons. Neurons receiving infrequent input pulses

cannot increase their internal states, and become inactive. The selection of the neural activity is performed by the inhibitory connection of the network.

2.2. IFN device consisting of SFQ circuits

The IFN devices we previously developed use a SFQ pulse as an impulse signal as shown in Fig. 2 [1]. The circuit is based on the leaky IFN model. It consists of an input subcircuit, a leaky integrator subcircuit, and an output subcircuit. The input subcircuit is a simple confluence buffer that collects SFQ pulses from other neuron devices and sends the pulses to the leaky integrator subcircuit. The leaky integrator subcircuit accumulates or stores input fluxoid quanta, and outputs an SFQ pulse through the inductor LB_1 coupled with LA_N when the number of stored fluxoid quanta exceeds a threshold. The output subcircuit sends the output SFQ pulse to other neurons and simultaneously produces reset pulses for the leaky integrator to initialize its own internal state.

Using this SFQ neuron device, we constructed neural networks that can perform pulsed-based computation for intelligent information signal processing.

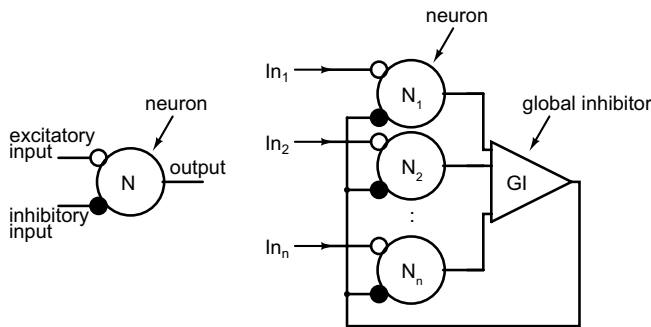

Fig. 1. Inhibitory neural network consisting of a number of neurons and a global inhibitor.

3. Construction of the pulsed neural network model and simulation results

We constructed an inhibitory neural network model using SFQ circuits. The entire circuit is depicted in Fig. 3. Three IFNs are used in this example. Each IFN circuit accepts input SFQ pulses and produces the corresponding output pulses. The global inhibitor, which consists of a 3-input confluence buffer and a 3-output splitter as shown in Fig. 3, receives any of the IFN outputs and produces an inhibitory pulse for all of the neurons.

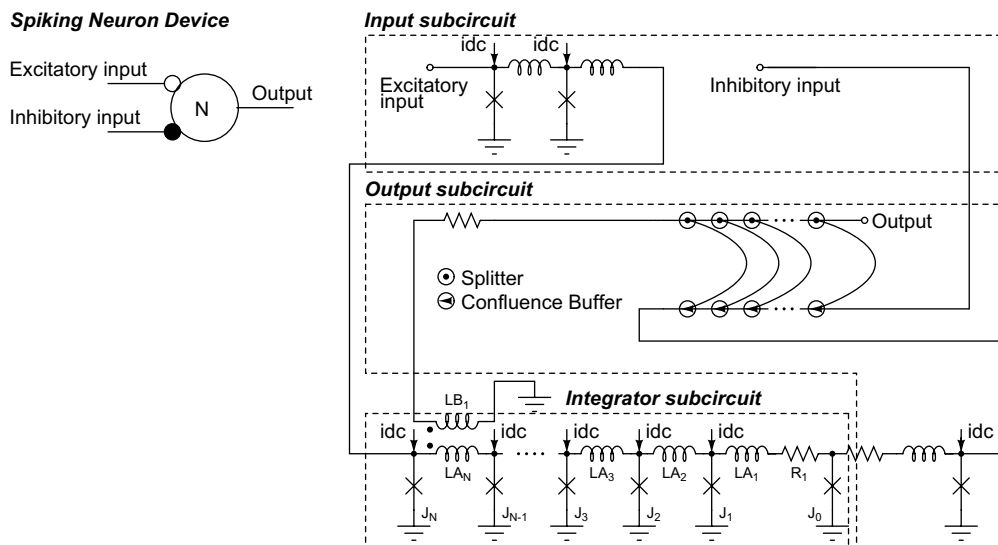

Fig. 2. Spiking neuron device consisting of SFQ circuits.

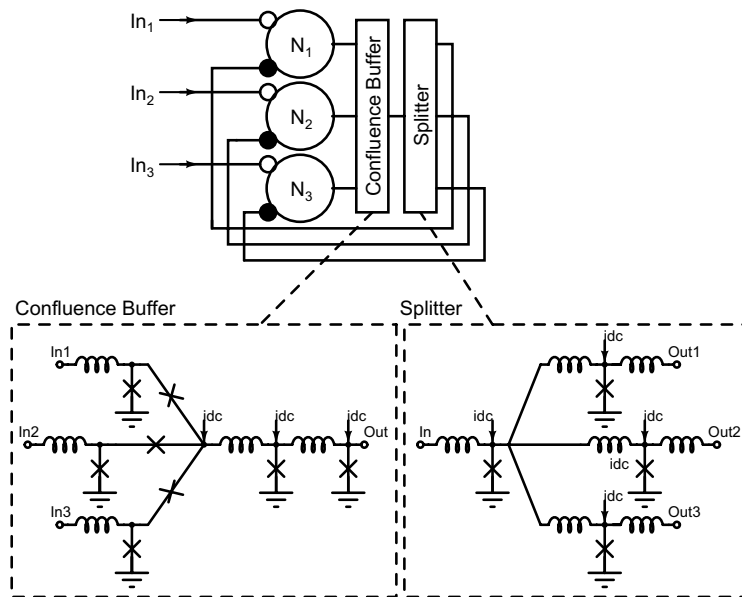

Fig. 3. Inhibitory neural network consisting of three spiking neurons, a 3-input confluence buffer, and a 3-output splitter.

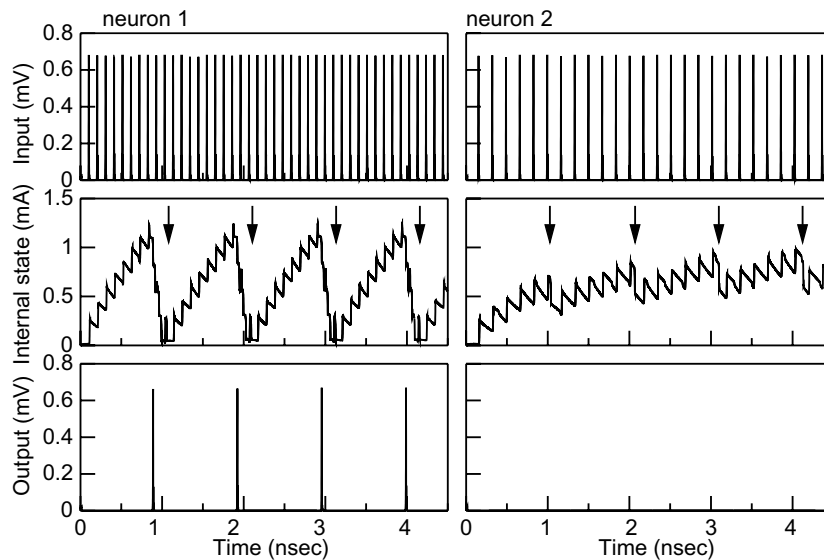

Fig. 4. Operation of the spiking neural network. Simulated results of (i) input pulses, (ii) internal state, and (iii) output pulse, for neuron N_1 and N_2 .

We confirmed the network operation through a computer simulation. The circuit parameters of each IFN device was: $N = 5$, $LA_N = 8 \text{ pH}$ ($N = 1-5$), $idc = 0.1 \text{ mA}$, and $R_1 = 50 \text{ m}\Omega$. The mutual induction coefficient between inductors LA_5 and LB_1 was assumed to be 0.7. For each Josephson junction, a parallel resistance of $4 \text{ }\Omega$ and a parallel capacitance of 0.1 pF were assumed. The critical current was 0.3 mA for junction J_0 and 0.13 mA for the other junctions.

The simulated operation is shown in Fig. 4. The waveforms for (i) the input pulses, (ii) the internal state, and (iii) the output of the neuron device are plotted for neurons N_1 and N_2 . Neuron N_1 received frequent pulse inputs and remained active, while neuron N_2 received infrequent pulse

inputs and became inactive. This was caused by the fact that IFNs receiving frequent input generate output pulses; the output pulses suppress the internal state of the other IFNs receiving infrequent pulses (see arrows in the middle plots in Fig. 4). Therefore, the internal state of IFNs receiving infrequent pulses was unable to reach the firing threshold. This is caused by the network-inhibition phenomenon, and enables the selection of neural activity.

4. Conclusion

An inhibitory pulsed neural network using SFQ circuits was developed for brain-like information processing. It consists of spiking neuron devices that are coupled to each

other through all-to-all inhibitory connections. The network selects neural activity. The operation of the neural network was confirmed by computer simulation. The spiking neuron devices receiving frequent pulse inputs remained active, while those receiving infrequent pulses became inactive. This was caused by the network-inhibition phenomenon. SFQ neuron devices can imitate the operation of the neural network.

References

- [1] T. Hirose, K. Ueno, T. Asai, Y. Amemiya, *Physica C* 445–448 (2006) 1020.
- [2] P. Fries, P.R. Roelfsema, A.K. Engle, P. Konig, W. Singer, *Proc. Natl. Acad. Sci. USA* 94 (1997) 12699.
- [3] T. Fukai, S. Kanemura, *Biol. Cybern.* 85 (2001) 107.
- [4] W. Maass, C.M. Bishop, *Pulsed Neural Networks*, MIT Press, Cambridge, 2001, p. 133.
- [5] T. Fukai, *Biol. Cybern.* 75 (1996) 453.